

CHECK VALVES

PISTON TYPE PRESSURE SEAL BONNET

The swing check valves and the tilting disc type check valves are not the only ones used in the high pressure, high temperature lines, typical of the power and steam generation industries. The process industry sometime also uses the herebelow described product. FLUITEK ORSENIGO VALVES can offer a piston type check valve line for high pressure, high temperature service. Construction is with Y-pattern (lifting direction inclined versus fluid centerline). Both forged and cast body construction are available.

Piston is either spring loaded or not, depending on customer choice. Ends configuration is quite normally with butt weld ends. Materials are to ASTM/ASME standards or EN standards, either harmonized or not, ranging from carbon steels, to low alloy steels, to austenitic stainless steels, to austenitic-ferritic stainless steels (duplex), to nickel alloys.

FLUITEK ORSENIGO VALVES offers, as a special added on feature, the possibility of simulating the fluidodynamic behavior of this type of valve, determining its proper functioning at certain specified flow rates, with customer furnished data of fluid conditions.

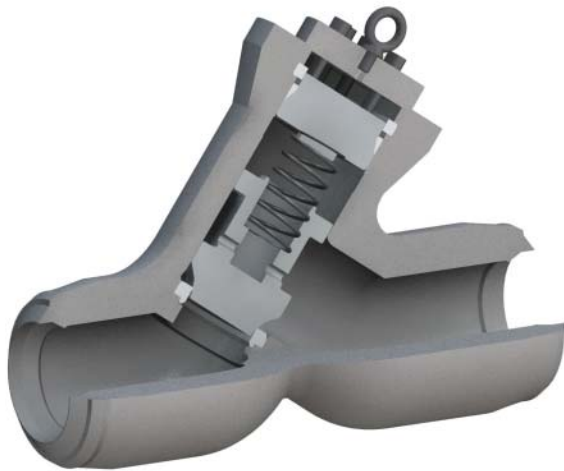

Pressure classes are normally in the high range:
 ANSI 900#, 1500#, 2500#.
 Special designs available for class 4500#.
 Intermediate classes available.
 A typical example is class 2500#
 normally supplied in accordance
 with this table, but not limited to.
 FLUITEK ORSENIKO VALVES has no
 dimensional limits, answering to all
 possible market requirements.

CHARACTERISTICS – ANSI 2500#

Nominal Size [inches]	Pressure Class	Bore diameter [mm]	Face to face [mm]	From center line to top [mm]	Weight [kg]
2"	2500	34	280	170	50
3"	2500	52	368	240	70
4"	2500	66	457	320	130
6"	2500	100	610	350	310
8"	2500	131	762	460	590
10"	2500	166	914	610	980
12"	2500	197	1041	650	1150
>12	On Application				